

Diagnostic Procedure without Diagnostic Trouble Code (DTC)

MANUAL TRANSMISSION AND DIFFERENTIAL (DIAGNOSTICS)

15. Diagnostic Procedure without Diagnostic Trouble Code (DTC)

A: CHECK PARKING BRAKE SWITCH

DIAGNOSIS:

Input signal circuit of parking brake switch is open or shorted.

TROUBLE SYMPTOM:

- It does not show a differential free tendency even when the parking brake switch is applied.
- Remains differential free even when the parking brake switch is released.

WIRING DIAGRAM:

Drivers control center differential control system <Ref. to WI-156, Driver's Control Center Differential Control System.>

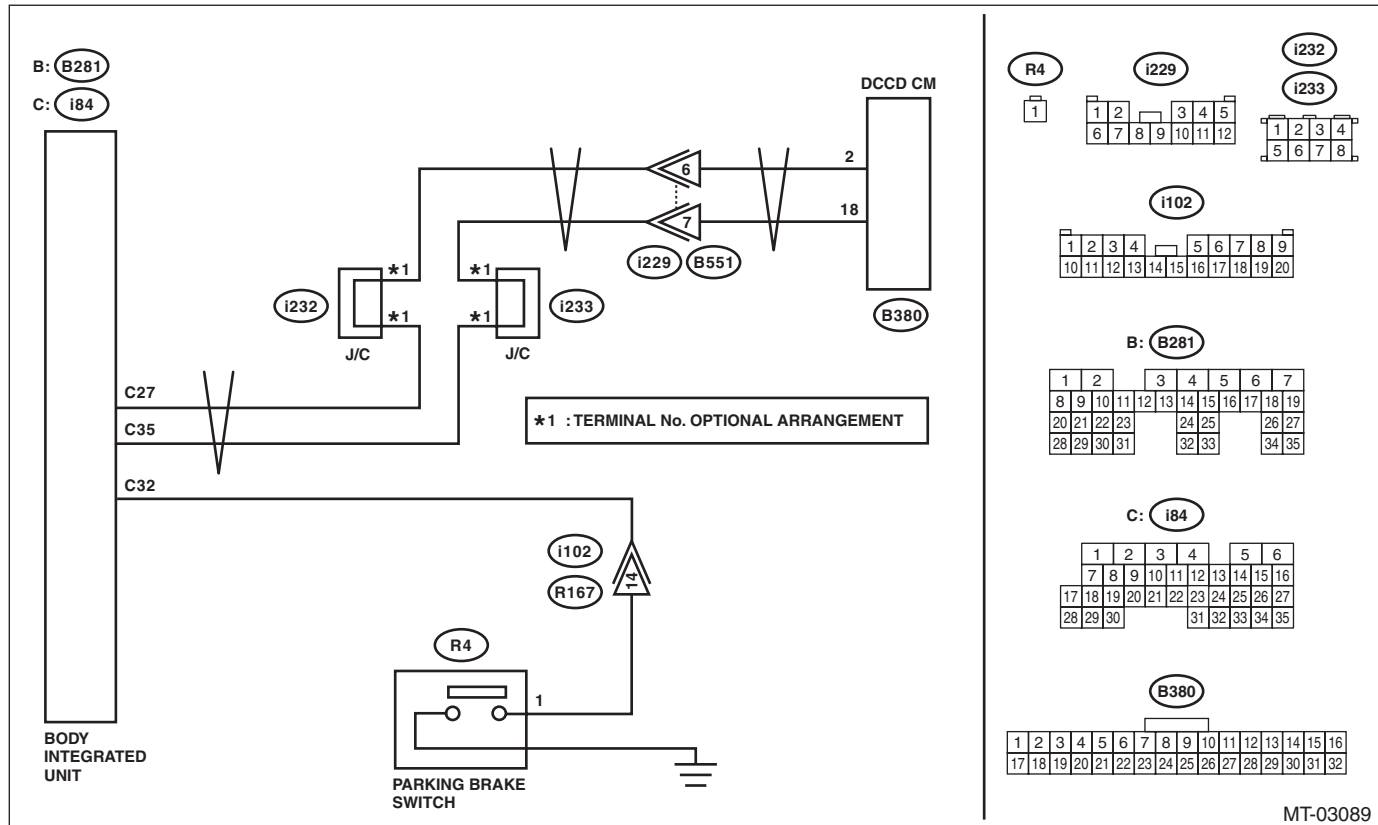

MT-03089

Step	Check	Yes	No
1 CHECK IGNITION CIRCUIT OF DCCD CONTROL MODULE. 1) Connect the Subaru Select Monitor to the vehicle. 2) Turn the ignition switch to ON. 3) Read the data of «Battery voltage» using Subaru Select Monitor.	Is the voltage 10 V or more?	Go to step 2.	Repair the open circuit of harness between fuse (F/B No. 12) and DCCD control module, or between fuse (F/B No. 12) and battery.
2 CHECK DTC.	Is DTC P0606 or U code displayed?	Perform the diagnosis according to DTC.	Go to step 3.
3 CHECK DCCD CONTROL MODULE. 1) Operate the parking brake lever. 2) Read the data of «Parking Position Switch» using Subaru Select Monitor.	Is the ON/OFF normally detected?	The parking brake switch circuit is currently operating properly.	Go to step 4.
4 CHECK BODY INTEGRATED UNIT. 1) Operate the parking brake lever. 2) Read the data of «Parking Position Switch» using Subaru Select Monitor.	Is the ON/OFF normally detected?	Go to step 7.	Go to step 5.

Diagnostic Procedure without Diagnostic Trouble Code (DTC)

MANUAL TRANSMISSION AND DIFFERENTIAL (DIAGNOSTICS)

Step	Check	Yes	No
5 CHECK HARNESS BETWEEN BODY INTEGRATED UNIT AND PARKING BRAKE SWITCH. 1) Turn the ignition switch to OFF. 2) Disconnect the connector from body integrated unit. 3) Check for open circuit, short circuit to battery and short circuit to ground between the body integrated unit connector and parking brake switch connector. Connector & terminal (i84) No. 32 — (R4) No. 1:	Is there any fault in the harness?	Repair or replace the harness.	Go to step 6.
6 CHECK PARKING BRAKE SWITCH. Measure the resistance between parking brake switch terminals.	Is the resistance less than 10 Ω when the parking brake lever is pulled? Is the resistance 1 MΩ or more when the parking brake lever is lowered?	Replace the body integrated unit.	Replace the parking brake switch.
7 CHECK DTC. Read the DTC of the LAN system using the Subaru Select Monitor.	Is DTC of CAN communication displayed?	Perform the diagnosis according to DTC. <Ref. to LAN(diag)-70, List of Diagnostic Trouble Code (DTC).>	Replace the DCCD control module. <Ref. to 6MT(TY85)-36, Driver's Control Center Differential Control Module.>

Diagnostic Procedure without Diagnostic Trouble Code (DTC)

MANUAL TRANSMISSION AND DIFFERENTIAL (DIAGNOSTICS)

B: CHECK DCCD MULTI SELECT SWITCH

DIAGNOSIS:

Input signal of DCCD multi select switch is open or shorted.

TROUBLE SYMPTOM:

- Does not enter the manual mode or auto mode when the mode change switch is pressed.
- Mode does not change in AUTO mode.
- Initial torque can not be changed in manual mode.

NOTE:

Other switch input can not be received if either mode change switch or C.DIFF +/- switch is stuck ON.

WIRING DIAGRAM:

Drivers control center differential control system <Ref. to WI-156, Driver's Control Center Differential Control System.>

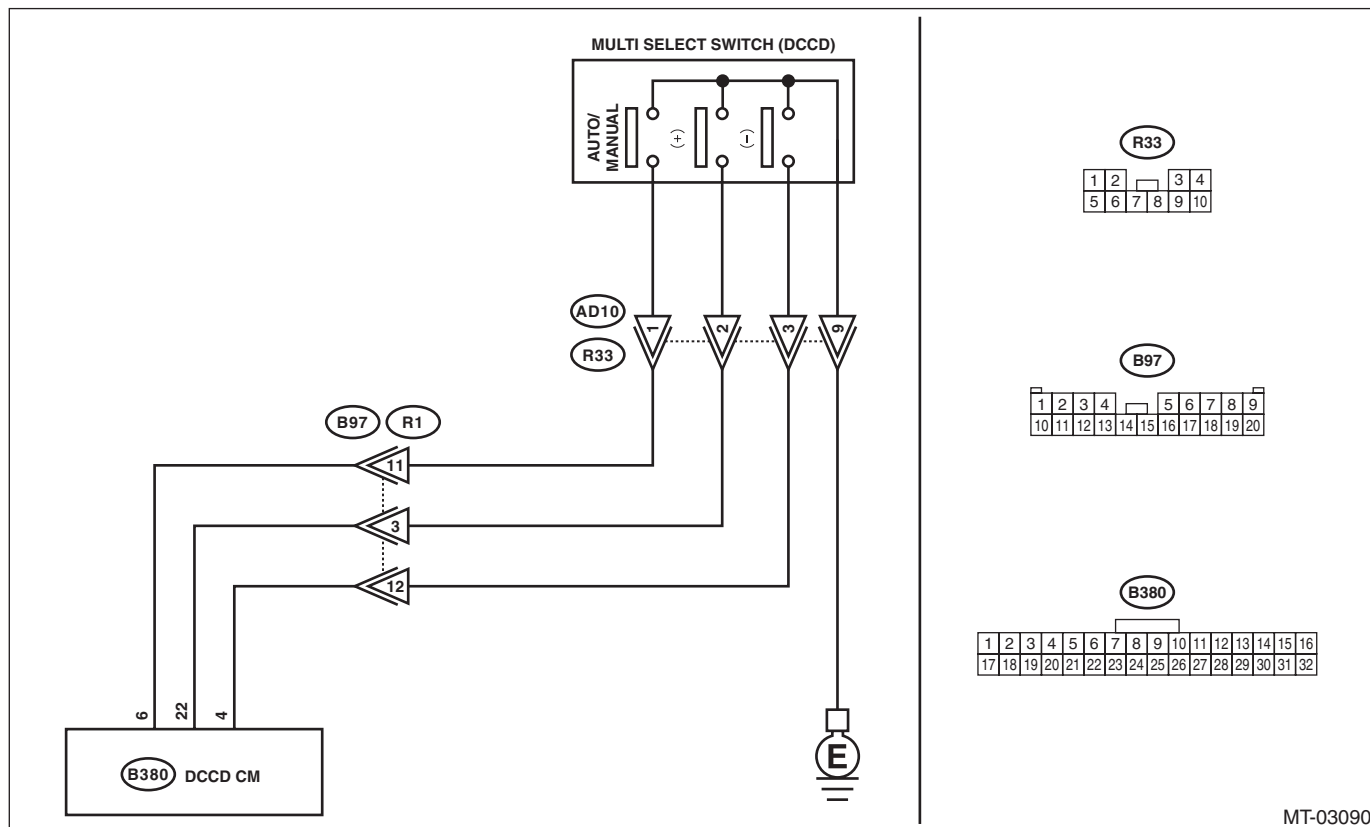

MT-03090

Step	Check	Yes	No
1 CHECK DCCD CONTROL MODULE. 1) Display the current data «AUTO/MANUAL Mode Switch» of DCCD control module, using Subaru Select Monitor. 2) Press the manual mode change switch.	Does the data change from OFF/ON?	Go to step 2.	Go to step 4.
2 CHECK DCCD CONTROL MODULE. 1) Display the current data «Up Switch» of DCCD control module, using Subaru Select Monitor. 2) Push the multi select switch toward plus.	Does the data change from OFF/ON?	Go to step 3.	Go to step 5.
3 CHECK DCCD CONTROL MODULE. 1) Display the current data «Down Switch» of DCCD control module, using Subaru Select Monitor. 2) Push the multi select switch toward minus.	Does the data change from OFF/ON?	The switch circuit is normal.	Go to step 6.

Diagnostic Procedure without Diagnostic Trouble Code (DTC)

MANUAL TRANSMISSION AND DIFFERENTIAL (DIAGNOSTICS)

Step	Check	Yes	No
4 CHECK MODE CHANGE SWITCH. 1) Disconnect the multi select switch connector. 2) Press the mode change switch. 3) Using the tester, measure the resistance between terminals. Connector & terminal (AD10) No. 1 — No. 9:	Is the resistance less than 1 Ω?	Go to step 7.	Replace the multi select switch. <Ref. to FU(STI)-55, SI-DRIVE (SUBARU Intelligent Drive) Selector.>
5 CHECK MULTI SELECT SWITCH. 1) Push the multi select switch toward plus. 2) Using the tester, measure the resistance between terminals. Connector & terminal (AD10) No. 2 — No. 9:	Is the resistance less than 1 Ω?	Go to step 7.	Replace the multi select switch. <Ref. to FU(STI)-55, SI-DRIVE (SUBARU Intelligent Drive) Selector.>
6 CHECK MULTI SELECT SWITCH. 1) Push the multi select switch toward minus. 2) Using the tester, measure the resistance between terminals. Connector & terminal (AD10) No. 3 — No. 9:	Is the resistance less than 1 Ω?	Go to step 7.	Replace the multi select switch. <Ref. to FU(STI)-55, SI-DRIVE (SUBARU Intelligent Drive) Selector.>
7 CHECK HARNESS. Use a tester to measure the resistance between the multi select switch harness connector and chassis ground. Connector & terminal (R33) No. 9 — Chassis ground:	Is the resistance less than 1 Ω?	Go to step 8.	Repair or replace the ground circuit.
8 CHECK HARNESS. 1) Disconnect the connector from DCCD control module. 2) Use a tester to measure the resistance between the DCCD control module and the multi select switch. Connector & terminal (R33) No. 1 — (B380) No. 6: (R33) No. 2 — (B380) No. 22: (R33) No. 3 — (B380) No. 4:	Is the resistance less than 1 Ω?	Go to step 9.	Repair or replace the open circuit of the harness.
9 CHECK HARNESS. Using the tester, measure the resistance between terminals. Connector & terminal (R33) No. 1 — (R33) No. 2: (R33) No. 1 — (R33) No. 3: (R33) No. 2 — (R33) No. 3:	Is the resistance 1 MΩ or more?	Go to step 10.	Repair or replace the short of harness.
10 CHECK HARNESS. Using the tester, measure the resistance between terminals. Connector & terminal (R33) No. 1 — Chassis ground: (R33) No. 2 — Chassis ground: (R33) No. 3 — Chassis ground:	Is the resistance 1 MΩ or more?	Replace the DCCD control module. <Ref. to 6MT(TY85)-36, Driver's Control Center Differential Control Module.>	Repair or replace the short of harness.